

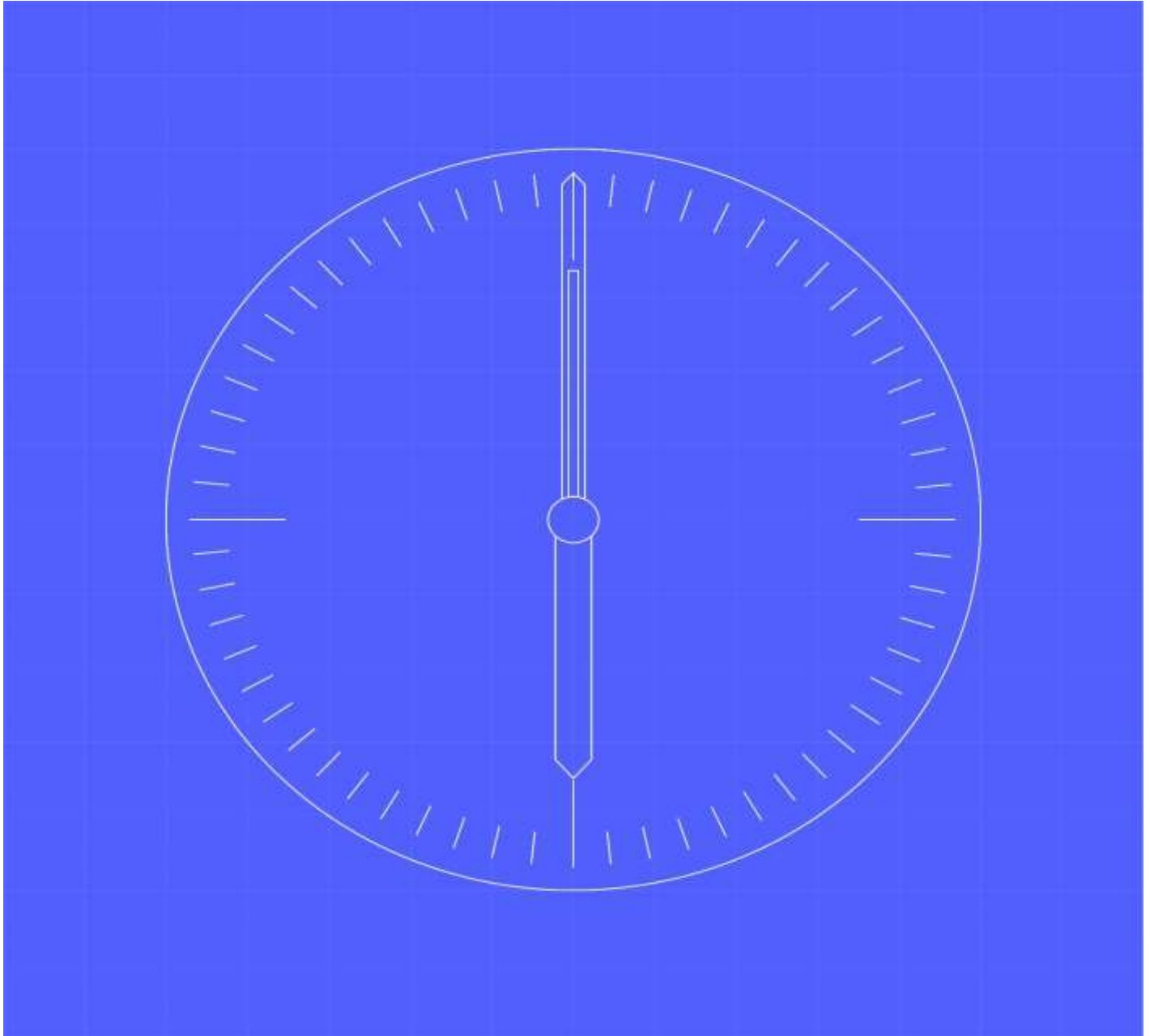

# [04] Migration Requirements and Processes



Document owner

**MHHS Programme**

Status:

**Draft**

Document number

**MHHS-DEL2430**

Date

**19 April 2024** ~~18 March 2023~~

Version

**0.2**

Classification

**Public**



# 1 Contents

<b>1 Contents</b>	<b>1</b>
1.1 Table of Figures	1
1.2 Change Record	2
1.3 References	2
1.4 Terminology	2
<b>2 Introduction</b>	<b>4</b>
2.1 Document purpose	4
2.2 Scope of this Document	4
<b>3 Intended Audience</b>	<b>4</b>
<b>4 Migration framework</b>	<b>6</b>
<b>5 High Level Requirements</b>	<b>7</b>
5.1 Summary	7
5.2 High-Level Requirements	8
<b>6 Business Process Models</b>	<b>9</b>
6.1 Level 0: MCC and Migration Schedule	9
6.2 Level 1: 01 Initialise Schedule-(BPM)	11
6.3 Level 1: 01 Initialise Schedule-(BPM Descriptions)	13
6.4 Level 1: 02 Maintain Schedule-(BPM)	14
6.5 Level 1: 02 Maintain Schedule-(BPM Description)	16
<b>7 Appendix</b>	<b>18</b>
7.1 MHHS Migration Business Process Model Notation Key	18

---

## 1.1 Table of Figures

Figure 1 - Migration Framework Document architecture .....	4
Figure 2 - Level 0 Business Process Model for MCC and Migration Schedule .....	9
Figure 3 - Level 1 BPM - 01-Initialise Schedule .....	12
Figure 4 - Level 1 BPM - 02 Maintain Schedule.....	15
Figure 5 - Business Process Model Notation Key .....	18

## 1.2 Change Record

Date	Author	Version	Change Detail
18/03/2024	Migration Team	v0.1	Draft for Industry Consultation
<u>19/02/2024</u>	<u>Migration Team</u>	v0.2	<u>Revised Draft for Assurance Meeting</u>

## 1.3 References

Document	Publisher	Published	Additional Information
REF-1 [01] Migration Framework Foundations v0.2	Migration Team	19/04/2024	Migration FW
REF-2 [02] Migration Framework - Principles and Guidelines v0.2	Migration Team	19/04/2024	Migration FW
REF-3 [03] Migration Capacity Calculations - Method Statements v0.2	Migration Team	19/04/2024	Migration FW
REF-4 [03a] Migration Capacity Calculations – Parameters v0.2	Migration Team	19/04/2024	Migration FW
REF-5 [04] Migration Requirements and Processes v0.2	Migration Team	19/04/2024	Migration FW
REF-6 [04a] Migration Business Process Models v0.2	Migration Team	19/04/2024	Migration FW
REF-7 MHHS-DEL961 – Migration Design Document v1.0	Migration Team	03/04/2023	
REF-8 MHHS-DEL953 – Data Assessment Report <u>v1.0</u>	Migration Team	21/02/2023	
REF-9 MHHS-DEL1128 – Migration, Cutover and Data Strategy v1.0	Migration Team	02/06/2023	
REF-10 MHHS-DEL1648 - Migration Thresholds Document v1.0	Migration Team	20/11/2023	
REF-11 MHHS-DEL813 – Overarching Test Data Approach and Plan <u>v1.0</u>	Testing Team	19/07/2023	
REF-12 MHHS-DEL1181 – Data Cleanse Plan <del>v4</del> <u>v2.0</u>	Migration Team	<del>24/02/2024</del> <u>24/07/2023</u>	
REF-13 MHHS-DEL1792 - M15 Acceptance Criteria v1.0	Migration Team	13/12/2023	

## 1.4 Terminology

Term	Description
BAU Process	This refers to a process within the MHHS arrangements as set out within the MHHS Core Design.
BSC	Balancing and Settlement Code
Central Services / Systems	MHHS Programme term referring to the parties and systems that comprise the supporting infrastructure for MHHS business processes and services, namely the Elexon Central Services, Electricity Enquiry Service, Data Service Provider, Central Switching Service, Data Transfer Network, and the Data Integration Platform.
CoA	Change of Agent
CoS	Change of Supplier
CSS	Central Switching Service
Daily Planned Migration Threshold	This is an industry-wide limit on the maximum planned for number of migrations that can take place on a given day under normal circumstances (200,000).
Data Cleanse Plan	The approach and activities required to improve and populate data prior to Migration start.
DC	Data Collector
DIP	Data Integration Platform
DS	Data Service
DSP	Data Services Provider
ECS	Elexon Central Services
EES	Electricity Enquiry Service
Export MPAN	An MPAN that exports energy to the grid from a premises.

<b>Term</b>	<b>Description</b>
Forward Migration	The process through which MPANs will move from legacy arrangements to MHHS arrangements.
IDNO	Independent Distribution Network Operator
Import MPAN	An MPAN that imports energy from the grid to a premises
ISD	Industry Standing Data
LDSO	Licensed Distribution System Operator
LDSO Portfolio Thresholds	Limits set for each LDSO based on the size of their portfolio, -ensuring balanced migration across different operators See MHHS-DEL1648 - Migration Thresholds Document v1.0
Legacy Arrangements	The existing arrangements set out under the BSC and REC. For the purposes of the Migration Design, this is primarily the REC Metering Services Schedule and the Balancing and Settlement Procedures related to Data Collection.
MCC	Migration Control Centre
MHHS	Market-Wide Half-Hourly Settlement
MHHS Arrangements	The new MHHS arrangements as set out in the MHHS Core Design Artefacts.
Migration Design	The technical articulation of how MPANs will move from legacy to new MHHS arrangements. See MHHS-DEL961 – Migration Design Document v1.0
MFW	Migration Framework
Migration Period	The period denoted by the Programme as occurring between the M11 and M15 milestones.
Migration Planning and Management Tool (MPMT)	Application to be developed for use by the MCC to manage the end to end migration process
MOP	Meter Operator
MPAN	Meter Point Administration Number
MPID	Market Participant Identifier
MS	Metering Service
MWG	Migration Working Group
NFR	Non-Functional Requirement
Primary MPAN	The MPAN, within a Related MPAN arrangement, for which a Switch is initiated, or a forward migration (via an IF-031) is initiated.
Qualified Supplier	A Supplier recognised in ISD as both having passed the relevant BSC qualification requirements; and declared that their service is operational within the MHHS arrangements.
Registration Service	The Registration Service is the LDSO service that holds Meter point standing data information about each MPAN within its Distribution Region. Data includes the BRP the processing and metering services appointed to the MPAN. It also includes information on the type of customer, the Measurement Class, Energisation Status and Line Loss Factor Class.
REC	Retail Energy Code
Reverse Migration	The process through which MPANs will move from MHHS arrangements to legacy arrangements.
Secondary MPAN	The MPAN, within a Related MPAN arrangement, for which a forward migration occurs when an IF-031 is received for a Primary MPAN.
Switch	The process by which a new Supplier Registration supersedes an existing Supplier Registration, managed by the CSS.
Upper Migration Threshold	This is an industry-wide limit on the maximum number of migrations that can take place on a given day under exceptional circumstances (300,000). See MHHS-DEL1648 - Migration Thresholds Document v1.0
Supplier Capacity Envelope	A daily profile covering the whole migration period detailing the maximum number of migrations a given Supplier in a LDSO may undertake.
Supplier Submission	A Supplier's forward view of planned migrations at LDSO level that falls within the Supplier Capacity Envelope provided and includes all MPANs within their portfolio.

## 2 Introduction

### 2.1 Document purpose

This document should be read in conjunction with the supporting artefacts.

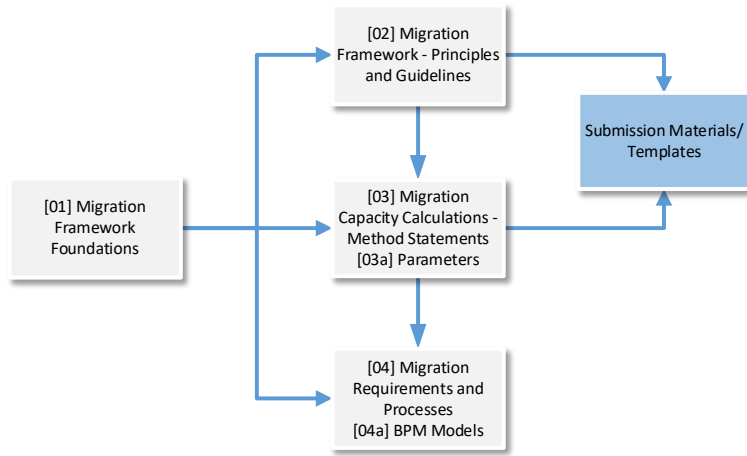

Figure 1 - Migration Framework Document architecture

The key activities to be described by the Migration Framework that will subsequently be managed by the Migration Control Centre will be the Initialisation of the Migration Schedule and its maintenance thereafter in response to changes to circumstances i.e. changes to qualification timelines and deviation from schedule.

### 2.2 Scope of this Document

The MHHS Migration Framework has 6 components, this document version currently covers component 1 and 2. The remaining components will be included in this document and consulted upon on Q2 2024.

#	Component	Included in document
01	Initialise Schedule	Yes
02	Maintain Schedule	Yes
03	Control and Monitor migration	To be included in future consultations
04	Manage Unused Capacity Allocation	No – To be included in future consultations
05	Data Analytics and Reporting	No – To be included in future consultations
06	Close Down Migration	No – To be included in future consultations

## 3 Intended Audience

These parties are:

- The Registration Services (including Service Providers);
- Suppliers;
- Data Collectors / Aggregators;
- Meter Operators;
- The DIP Service Provider;
- Metering Services (i.e., MSS, MSA);
- Data Services (i.e., SDS, ADS, UMSDS);
- EES;

- LDSOs (i.e., DNOs and iDNOs);
- Meter Administrators;
- The DCC, operating Smart Metering and CSS;
- ESO;
- Elexon Central Services (ECS);
- Electralink (DTN);
- REC and BSC Performance Assurance Boards;
- UMSOs.

## 4 Migration framework

To manage the migration complexities and set the Migration phase up for a success a Migration Framework is required. The Framework will be developed and agreed with industry and will guide the Migration Control Centre activities.

The Migration framework comprises of 6 components.

#	Component	Description
01	<b>Initialise Schedule</b>	Steps to develop and agree v1 of schedule. Setting up the initial migration plan, factoring in all Supplier Weekly Migration Plans to establish a feasible MHHS Migration Schedule for all Participants.
02	<b>Maintain Schedule</b>	After the creation of the v1 of schedule. Regular updating and adjusting the MHHS Migration Schedule to reflect changes such as Qualification Date, ensuring it remains realistic and achievable. During Migration Window factoring in Supplier progress and outturn to further inform MHHS Migration Schedule feasibility and make necessary adjustments,
03	<b>Control and Monitor migration</b>	Monitoring and managing execution according to the Daily MHHS Migration Schedule. Reviewing MHHS Migration Schedule vs Actual Supplier Migration <del>performance and identifying performance, identifying,</del> and addressing deviations promptly. Managing migration constraints, risks and resolving issues.
04	<b>Manage Unused Capacity Allocation</b>	Sharing identified excess capacity to ensure use as much of the available capacity as possible.
05	<b>Data Analytics and Reporting</b>	Analyse migration data to provide insights and regular reports on migration progress, challenges, and achievements. Includes the collection, aggregation, analysis, and dissemination of migration data, reports and analytics to support a data-led <del>decision-making</del> <del>decision-making</del> and control process for MHHS Migration.
06	<b>Close Down Migration</b>	Close-down reporting and decommission MCC, and finalise documentation.

# 5 High Level Requirements

## 5.1 Summary

### Industry Participants / Roles

Participant Type	Role	Prior to MHHS Migration	In MHHS Market
Energy Suppliers	Suppliers	Estimated consumption billing; non-half-hourly consumption data.	Real-time consumption billing; Half-hourly data and more dynamic energy supply models.
Data Service Providers	Agents	Data Collectors & Aggregators: Collected and aggregated energy usage data, often manually, for billing; Traditional data handling	Data Service Providers: Include advanced analytics services handling high-frequency, handling of high volumes of data from smart meters.
Metering Agents		Less frequent data collection; Mainly manual.	Frequent, automated data collection; Smart meters, Advanced meters.
Distributors (DNOs / iDNOs)	LDSOs	Focused on distribution and transmission with limited real-time consumption data.	Enhanced visibility and management of demand with real-time data.
Regulatory Bodies	Code Bodies	Standard regulatory oversight with standard regulations based on non-real-time data.	Increased focus on real-time data compliance and analysis; Increased emphasis on data compliance, security, and efficient market operation.
Consumers	Customers	Limited engagement in energy usage patterns.	Greater involvement and potential for cost-saving through demand response.

### 5.1.1 Migration Participants / Roles

Role	Description
Migration Control Centre	<p><b>Pre-M10</b> Set-up framework and foundation for migration to MHHS</p> <p><b>Post M10</b> Oversight of MHHS Migration Programme execution during migration window; Transition to BAU.</p> <p><b>Post M15</b> Close down of MCC</p>



## 5.2 High-Level Requirements

This section covers fundamental expectations and objectives for all stakeholders involved in the MHHS Programme's migration process. It serves as a blueprint for future discussions and more detailed elaboration of requirements and to support the identification of any potential system requirements at a later stage.

#	Business Process	Sub-Category	Requirement Description	Role	Rationale
REQ-01.01	01 Initialize Schedule	Maintain Schedule	Develop an initial migration schedule (MHHS Migration schedule v1) that aligns with system thresholds and capacity. (Weekly Granularity)	MCC	Ensures that the MHHS Migration schedule v1 is developed early with information available to allow relevant Participants planning and resourcing.
REQ-01.02	01 Initialize Schedule	Data Collection	Set up a system for participants to submit their migration preferences and migration plans	Industry Participants MCC	Allow MCC to systematically collect and validate Migration Plans from Participants in a deterministic, efficient and robust manner.
REQ-01.03	01 Initialize Schedule	Fairness	Ensure the initial MHHS Migration schedule v1 reflects a fair pragmatic allocation of available migration capacity.	MCC	Aligns with MFW Principles and included an intelligent pragmatic way to support Participant with lower volume portfolios that may otherwise be disadvantaged by a model that is primarily designed for large Supplier and LDSOs.
REQ-02.01	02 Maintain Schedule	Maintain Schedule	Update the MHHS Migration schedule according to a pre-agreed Sprint cadence to reflect changes in participant qualification and readiness status, migration outturn, and customer impacts.	MCC	Keeps the MHHS Migration schedule current and reflective of current Market conditions and evolving Participants needs.
REQ-02.02	02 Maintain Schedule	Data Collection	Implement a feedback mechanism/protocol for participants to communicate issues impacting their schedule in a timely manner.	Industry Participants MCC	Enables the MCC to make rapid, informed decisions and take timely corrective action on potential/actual MHHS Migration schedule impacts.
REQ-02.03	02 Maintain Schedule	Fairness	Ensure the schedule revisions adhere to the Migration Framework Principles including fairness and transparency.	MCC	Aligns with MFW Principles, and ensures continuity during migration window.
REQ-03.01	03 Control and Monitor	Data Collection, Oversight	Automated gathering and processing of information to digest and interpret migration progress and schedule adherence.	MCC	Allows for proactive management and early detection of emerging risks and issues.
REQ-03.02	03 Control and Monitor	Oversight	Create a system for participants to report schedule deviations for timely MCC intervention.	Industry Participants MCC	Facilitates swift resolution of deviations to minimize impact on the migration timeline.
REQ-04.01	04 Manage Unused Capacity Allocation	Capacity Adjustment and Reallocation	Design a system that dynamically adjusts capacity allocations based on real-time migration data.	MCC	Provides clear mechanism to apportion identified spare capacity to Participants that are able to <b>NOTE:</b> There primary reallocation will initiate soon after the MHHS Migration schedule is issued. However, some exceptional scenarios may be at relatively short notice e.g. 2-3 days.
REQ-04.02	04 Manage Unused Capacity Allocation	Capacity Adjustment and Reallocation	Establish a process for participants to request extra capacity or return unused capacity for reallocation.	Industry Participants MCC	Implementation of a set of pre-agreed rules for unused capacity allocation.
REQ-05.01	05 Data Analytics and Reporting	Data Dissemination	Develop a <del>comprehensive</del> dashboard for migration analytics, including progress, capacity, and performance metrics.	MCC	Provides stakeholders at the various levels required with actionable insights into migration operations.
REQ-05.02	05 Data Analytics and Reporting	Data Dissemination	Implement a reporting system to generate and distribute detailed migration status reports, including deviations and actions taken.	MCC	Keeps stakeholders informed and maintains transparency throughout the migration process.

## 6 Business Process Models

### 6.1 Level 0: MCC and Migration Schedule

#### 6.1.1 Level 0: MCC and Migration Schedule (BPM)

The figure below shows the high-level interactions and stages of the Migration Control Centre (MCC)

The Level 0 processes are described in Section: Level 0: MCC and Migration Schedule (BPM Description)

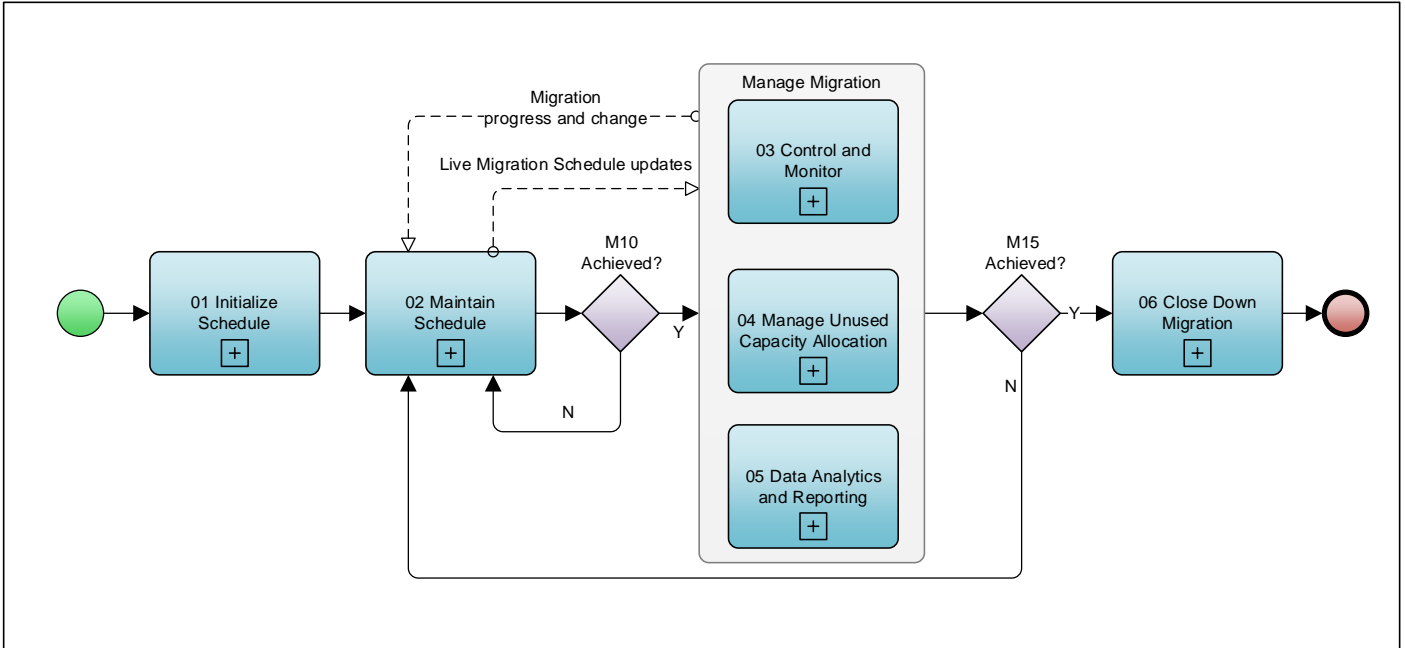

Figure 2 - Level 0 Business Process Model for MCC and Migration Schedule

6.1.2 Level 0: MCC and Migration Schedule (BPM Description)

NOTE: Processes shaded grey in the table will be detailed in upcoming consultations, the current descriptions are preliminary.

#	Process Name	Input	Process Details	Output
01	Initialize Schedule	<ul style="list-style-type: none"> <li>Finalised migration framework</li> <li>Qualification Dates</li> <li>Supplier Preferences</li> <li>Migration Plans at                             <ul style="list-style-type: none"> <li>Supplier (MPID) and LDSO(MPID) Level</li> <li>Weekly Granularity</li> <li>Indication of MPAN type distribution</li> </ul> </li> </ul>	<b>Following MFW:</b> <ul style="list-style-type: none"> <li>Create Supplier Capacity Envelopes to indicate capacity available to each Supplier</li> <li>Process Supplier Migration plan to generate MHHS Migration Schedule v1.</li> <li>Distribute to Participants</li> </ul>	<ul style="list-style-type: none"> <li>MHHS Migration Schedule v1</li> </ul>
02	Maintain Schedule	<ul style="list-style-type: none"> <li>Updated Supplier Plans (based in MCC Supplier Capacity Envelope updates)</li> <li>Daily/Weekly Granularity plans following MFW</li> <li>Quantified Impact to Migration schedule from the Control and Monitor Process including.</li> <li>Migration Outturn</li> <li>Migration and related systems performance</li> <li>Migration Progress/plan deviation</li> <li>Unused Capacity Allocations</li> </ul>	<b>Following MFW:</b> <ul style="list-style-type: none"> <li>Regularly update MHHS Migration Schedule following Migration Sprint Timeline.</li> <li>Regularly review and update the schedule to accommodate changes and incorporate:                             <ul style="list-style-type: none"> <li>Migration progress</li> <li>Participant qualification and readiness including migration start dates and service activation schedule</li> <li>Service performance</li> <li>Changes to supplier migration plans</li> </ul> </li> </ul> By re-issuing Supplier Capacity Envelopes and receiving updated Migration Plans within revised migration capacity restrictions. ←Suppliers provide/update list of MHHS Quantified Agents to be involved in their Migration Plans.	<ul style="list-style-type: none"> <li>Next iteration of MHHS Migration Schedule</li> <li>Data to inform 03 Control and Monitor</li> <li>Data to inform Manage Unused Capacity Allocation</li> <li>Data for 05 Data Analytics and Reporting</li> </ul>
03	Control and Monitor	<ul style="list-style-type: none"> <li>Migration progress/performance data</li> <li>Service Management reports</li> <li>Notice of significant events potentially impacting migration schedule</li> <li>Significant plan deviations</li> <li>Participants behaving outside of MFW Principles</li> </ul>	<ul style="list-style-type: none"> <li>Monitor migration activities</li> <li>Manage deviations through control mechanisms,</li> <li>Communicate migration status and trends</li> </ul>	<ul style="list-style-type: none"> <li>Deviation management updates</li> <li>Issue escalations</li> </ul>
04	Manage Unused Capacity Allocation	<ul style="list-style-type: none"> <li>Migration progress/performance data</li> <li>Supplier Daily Migration Plans</li> <li>Additional Capacity Requests from Suppliers</li> <li>Spare/Unused capacity details</li> </ul>	<ul style="list-style-type: none"> <li>Regular Unused Capacity Allocation Request Process</li> <li>Allocate Unused Capacity calculation and disseminate Unused Capacity allocations</li> <li>Ad-hoc process to allocates short-notice availability of spare capacity</li> </ul>	<ul style="list-style-type: none"> <li>Supplier daily capacity allocations as part of Migration Schedule Sprint Cadence</li> <li>Ad-hoc daily capacity allocations</li> </ul>
05	Data Analytics and Reporting	<ul style="list-style-type: none"> <li>Migration data, stakeholder feedback</li> <li>Same as Control and Monitor</li> </ul>	<ul style="list-style-type: none"> <li>Analyse migration data for insights; generate and distribute reports on status, deviations, and performance.</li> </ul>	<ul style="list-style-type: none"> <li>Regular/frequent monitoring reports</li> <li>Migration analytics</li> <li>Dashboards</li> </ul>
06	Close Down Migration	<ul style="list-style-type: none"> <li>M15 Milestone confirmation</li> <li>Migration Reports</li> </ul>	<ul style="list-style-type: none"> <li>Close-down reporting and decommission MCC, and finalise documentation</li> </ul>	<ul style="list-style-type: none"> <li>Decommissioned MCC systems</li> <li>Final Migration Reports and project closure</li> </ul>

## 6.2 Level 1: 01 Initialise Schedule-(BPM)

The Level 1 processes (in blue) are the primary interactions with the MCC and are described in Section: Level 1: 01 Initialise Schedule-(BPM Descriptions).

NOTE: The processes (in white) are indicative process step where the process name conveys the expected activity.

For a higher resolution version of the model below:

- See [04a] Migration Business Process Models

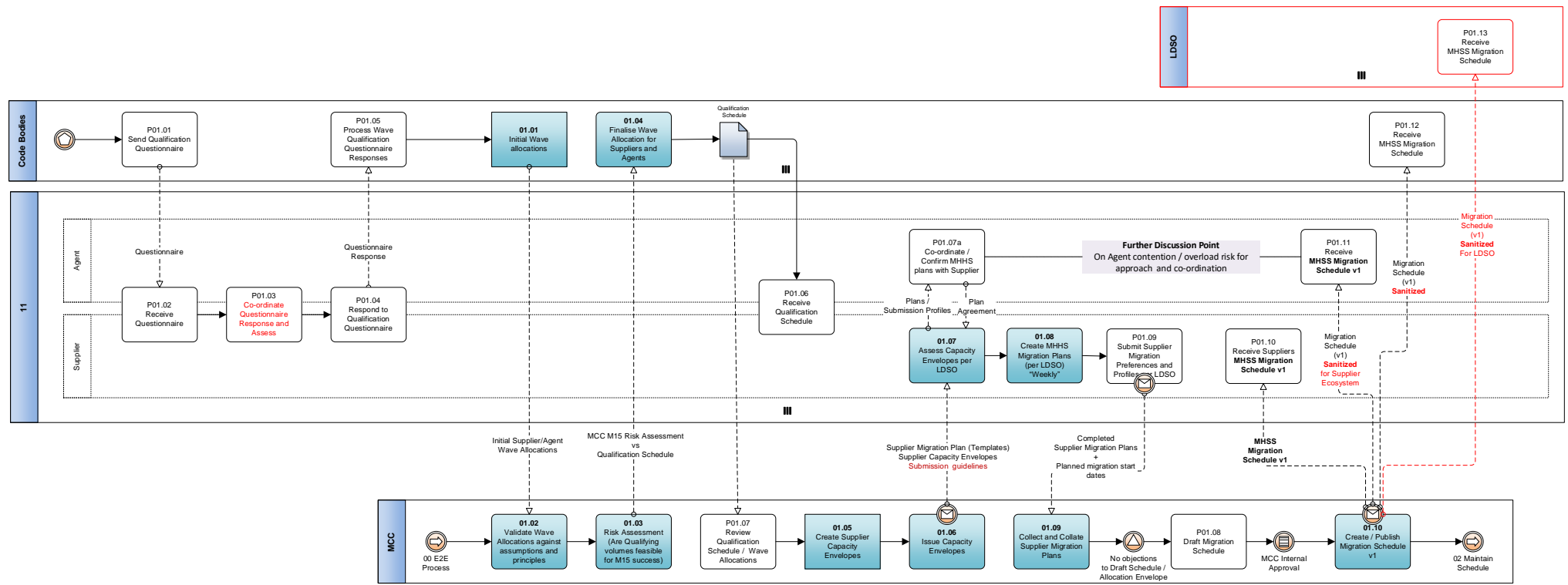

[04] Migration Requirements and Processes MHHS-DEL2430-[04] Migration Requirements and Processes Mhhs-DEL2430-[04] Migration Requirements And Processes

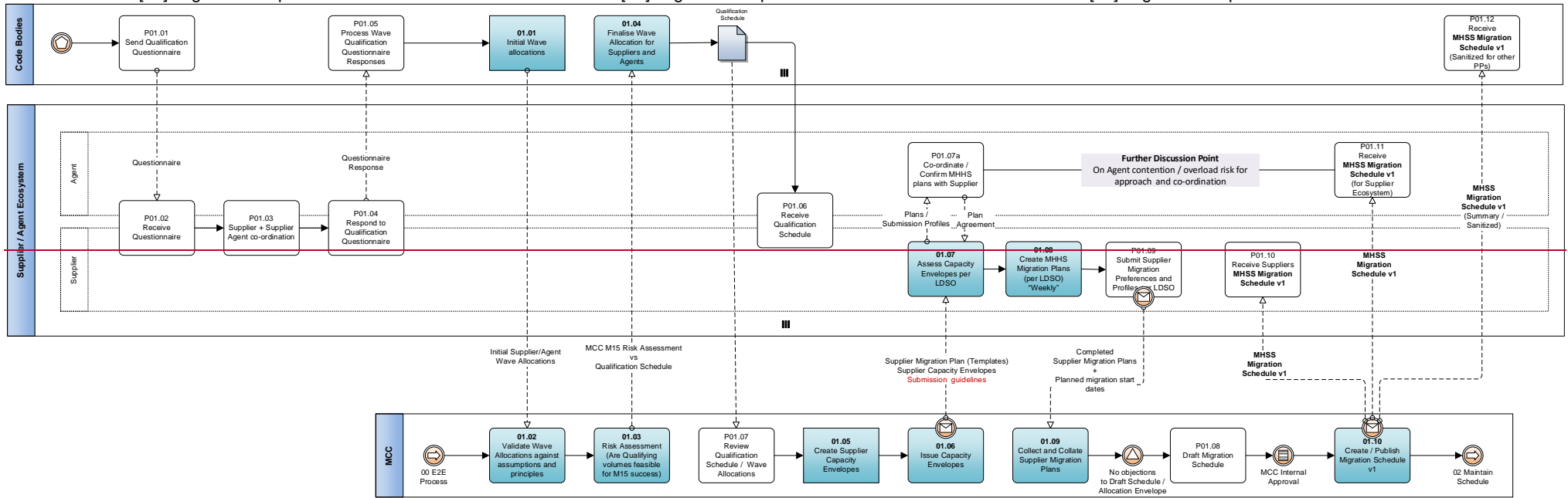

Figure 3 - Level 1 BPM - 01-Initialise Schedule

### 6.3 Level 1: 01 Initialise Schedule-(BPM Descriptions)

#	Process Name	Role	Input	Process Details	Output
1.01	Initial Wave allocations	Code Bodies	<ul style="list-style-type: none"> <li>Upstream industry consultation</li> </ul>	<ul style="list-style-type: none"> <li>Early sight of Wave allocation to allow early identification of potential migration scheduled conflicts</li> </ul>	<ul style="list-style-type: none"> <li>Initial Supplier/Agent Wave Allocations</li> </ul>
1.02	Validate Wave Allocations against assumptions and principles	MCC	<ul style="list-style-type: none"> <li>Initial Supplier/Agent Wave Allocations</li> </ul>		
1.03	Risk Assessment (Are Qualifying volumes feasible for M15 success)	MCC	<ul style="list-style-type: none"> <li>Reviewed Supplier/Agent Wave Allocations</li> </ul>	<ul style="list-style-type: none"> <li>Risk Mitigation step to provide an initial view of impact of Qualification timeline on M15 feasibility.</li> </ul>	<ul style="list-style-type: none"> <li>MCC M15 Risk Assessment vs Qualification Schedule</li> </ul>
1.04	Finalise Wave Allocation for Suppliers and Agents	Code Bodies	<ul style="list-style-type: none"> <li>MCC M15 Risk Assessment -vs Qualification Schedule</li> </ul>		<ul style="list-style-type: none"> <li>Confirmed Qualification Wave details</li> </ul>
1.05	Create Supplier Capacity Envelopes	MCC	<ul style="list-style-type: none"> <li>Confirmed Qualification Wave details</li> </ul>	<ul style="list-style-type: none"> <li>Use Supplier Preference, Migration Plans with Supplier Capacity Allocation Method to define ALL Suppliers Capacity Envelopes at an LDSO Level.</li> </ul>	<ul style="list-style-type: none"> <li>Supplier Capacity Envelopes</li> </ul>
1.06	Issue Capacity Envelopes	MCC	<ul style="list-style-type: none"> <li>Supplier Capacity Envelopes</li> </ul>	<ul style="list-style-type: none"> <li>Send each Supplier their generated plans in pre-agreed format.</li> </ul>	<ul style="list-style-type: none"> <li>Supplier Capacity Envelopes</li> <li>Supplier Migration Plan (Templates)</li> <li>Submission -guidelines</li> </ul>
1.07	Assess Capacity Envelopes per LDSO	Supplier	<ul style="list-style-type: none"> <li>Supplier Capacity Envelopes</li> </ul>	<ul style="list-style-type: none"> <li>Review Supplier MHHS Migration plans and confirm in-lime with Migration Framework Principles.</li> </ul>	<ul style="list-style-type: none"> <li>Migration Submission Boundaries (Daily)</li> </ul>
1.08	Create MHHS Migration Plans (per LDSO)	Supplier	<ul style="list-style-type: none"> <li>Supplier Capacity Envelopes</li> <li>Supplier Migration Plan (Templates)</li> <li>Submission guidelines</li> </ul>	<ul style="list-style-type: none"> <li>As required create or adapt Suppliers' own Migration Submission Schedule within boundaries defined in the Suppliers' Capacity Envelopes.</li> </ul>	<ul style="list-style-type: none"> <li>Completed Supplier Migration Plans</li> <li>Planned migration start dates</li> </ul>
1.09	Collect and Collate Supplier Migration Plans	MCC	<ul style="list-style-type: none"> <li>Supplier Migration Plans</li> <li>Supplier / Agent Planned migration start date</li> </ul>	<ul style="list-style-type: none"> <li>MPMT Stores all Suppliers Migration Plans with profile data</li> </ul>	<ul style="list-style-type: none"> <li>Stored Supplier Migration Plans and Profiles per LDSO</li> </ul>
1.10	Create / Publish Migration Schedule v1	MCC	<ul style="list-style-type: none"> <li>Stored Supplier Migration Plans and Profiles per LDSO</li> </ul>	<ul style="list-style-type: none"> <li>Process Supplier Migration Plans in accordance with their Profile data and preference. Generate a balanced MHHS Migration Schedule following the MFW Principles.</li> </ul>	<ul style="list-style-type: none"> <li>Confirmed and rebalanced Migrations Plan (if required)</li> <li>Supplier Migration Plans per LDSO</li> <li>MHSS Migration Schedule v1</li> <li><a href="#">Summary / Aggregate sanitized plans sent to LDSOs, Code Bodies and other Participants with permission to view</a></li> </ul>

## 6.4 Level 1: 02 Maintain Schedule-(BPM)

The Level 1 processes (in blue) are the primary interactions with the MCC and are described in Section: Level 1: 02 Maintain Schedule-(BPM Description)..

NOTE: The processes (in white) are indicative Discussion process step where the process name conveys the expected activity.

For a higher resolution version of the model below:

See [04a] Migration Business Process Models

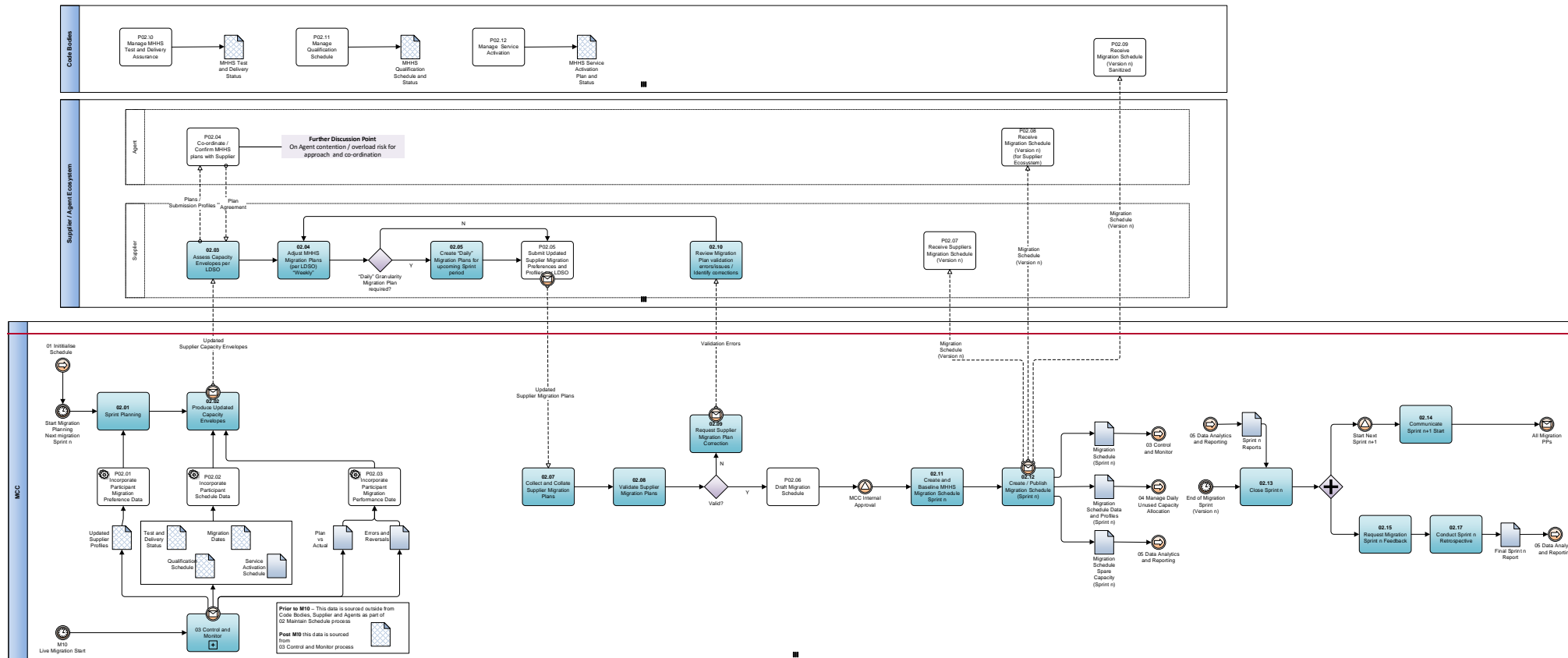

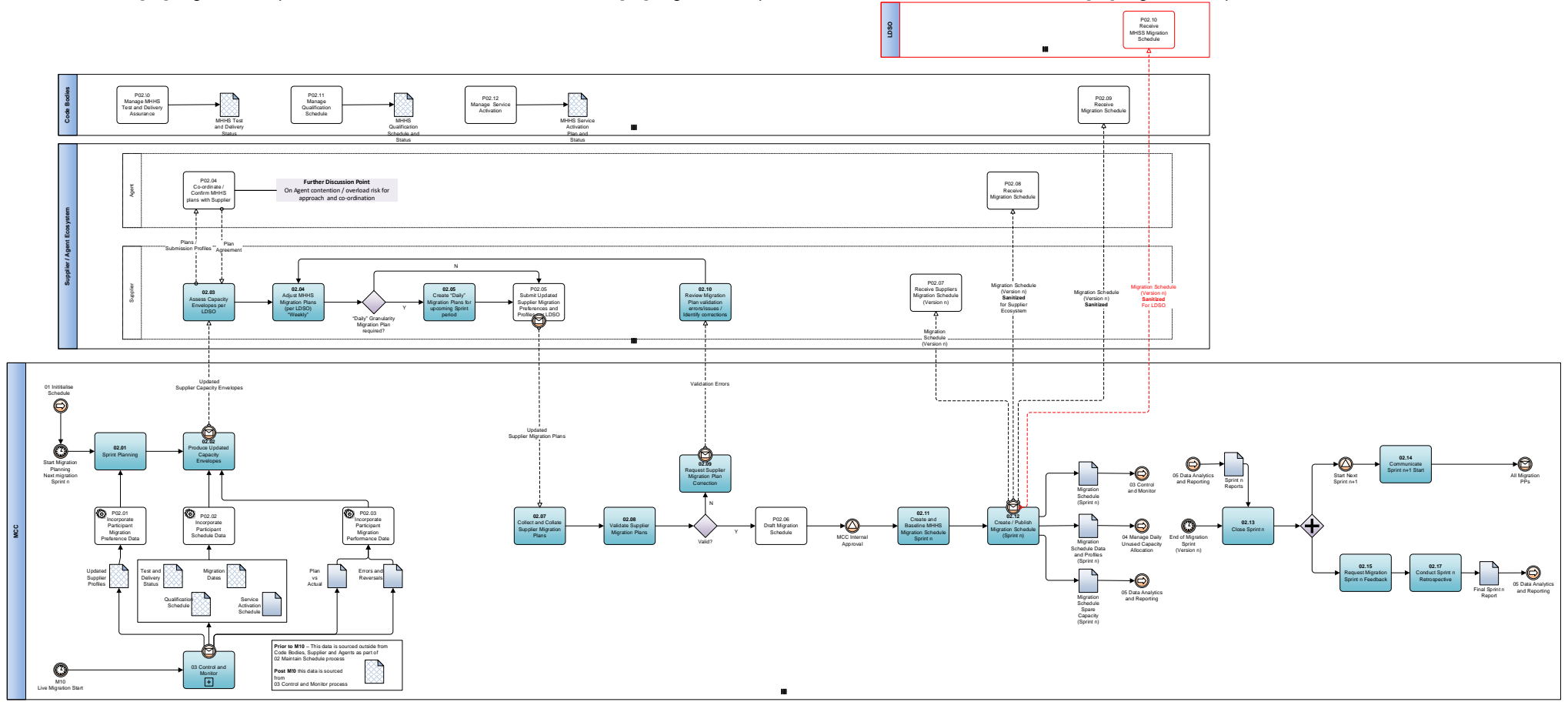

Figure 4 - Level 1 BPM - 02 Maintain Schedule



## 6.5 Level 1: 02 Maintain Schedule-(BPM Description)

#	Process Name	Role	Input	Process Details	Output
02.01	<b>Sprint Planning Initiation</b>	<b>MCC</b>	<ul style="list-style-type: none"> <li>Start of new sprint signal</li> <li>Feedback from previous sprint</li> </ul>	<ul style="list-style-type: none"> <li>The MCC initiates sprint planning by reviewing previous sprint feedback and signalling the start of a new sprint planning phase.</li> </ul>	<ul style="list-style-type: none"> <li>Sprint Planning Kick-off Notification</li> </ul>
02.02	<b>Produce Updated Capacity Envelopes</b>	<b>MCC</b>	<ul style="list-style-type: none"> <li>Service performance data</li> <li>Qualification schedules</li> <li>Previous sprint migration data</li> <li>Stakeholder feedback</li> </ul>	<ul style="list-style-type: none"> <li>Analyse various inputs to reassess and update the capacity envelopes according to data available.</li> </ul>	<ul style="list-style-type: none"> <li>Updated Supplier Capacity Envelopes</li> </ul>
02.03	<b>Supplier Capacity Review</b>	<b>Supplier</b>	<ul style="list-style-type: none"> <li>Updated Supplier Capacity Envelopes</li> </ul>	<ul style="list-style-type: none"> <li>Suppliers review the new capacity envelopes against their operational capabilities and migration goals, identifying potential adjustments needed.</li> </ul>	<ul style="list-style-type: none"> <li>Supplier Capacity Review Report</li> </ul>
02.04	<b>Adjust MHHS Migration Plans (Weekly)</b>	<b>Supplier</b>	<ul style="list-style-type: none"> <li>Supplier Capacity Review Report</li> </ul>	<ul style="list-style-type: none"> <li>Suppliers adjust their weekly migration plans based on the new capacity envelopes and their review, ensuring alignment with overall migration goals.</li> </ul>	<ul style="list-style-type: none"> <li>Adjusted Weekly Supplier Migration Plans</li> </ul>
02.05	<b>Develop Daily Migration Plans for Sprint n</b>	<b>Supplier</b>	<ul style="list-style-type: none"> <li>Adjusted Weekly Supplier Migration Plans</li> </ul>	<ul style="list-style-type: none"> <li>Suppliers detail their migration activities in daily plans for the upcoming sprint, ensuring adherence to the adjusted weekly plans and capacity envelopes.</li> </ul>	<ul style="list-style-type: none"> <li>Daily Supplier Migration Plans for Sprint n</li> </ul>
02.06	<b>Submit Updated Migration Plans</b>	<b>Supplier</b>	<ul style="list-style-type: none"> <li>Daily Supplier Migration Plans for Sprint n</li> </ul>	<ul style="list-style-type: none"> <li>Suppliers submit their detailed daily migration plans to the MCC for review and validation.</li> </ul>	<ul style="list-style-type: none"> <li>Submitted Supplier Migration Plans for Sprint n</li> </ul>
02.07	<b>Collect and Collate Supplier Migration Plans</b>	<b>MCC</b>	<ul style="list-style-type: none"> <li>Submitted Supplier Migration Plans for Sprint n</li> </ul>	<ul style="list-style-type: none"> <li>The MCC collects and organizes all submitted daily migration plans, preparing them for validation.</li> </ul>	<ul style="list-style-type: none"> <li>Collated Migration Plans for Sprint n</li> </ul>
02.08	<b>Validate Supplier Migration Plans</b>	<b>MCC</b>	<ul style="list-style-type: none"> <li>Collated Migration Plans for Sprint n</li> </ul>	<ul style="list-style-type: none"> <li>Review and validate the submitted plans against the migration framework, business rules, and capacity constraints.</li> </ul>	<ul style="list-style-type: none"> <li>Validation Report &amp; Request for Plan Corrections</li> </ul>
02.09	<b>Review and Correct Migration Plans</b>	<b>Supplier</b>	<ul style="list-style-type: none"> <li>Request for Plan Corrections</li> </ul>	<ul style="list-style-type: none"> <li>Suppliers review any issues or errors highlighted by the MCC and make necessary corrections to their migration plans.</li> </ul>	<ul style="list-style-type: none"> <li>Corrected Supplier Migration Plans</li> </ul>
02.10	<b>Finalize and Baseline MHHS Migration Schedule</b>	<b>MCC</b>	<ul style="list-style-type: none"> <li>Corrected Supplier Migration Plans</li> </ul>	<ul style="list-style-type: none"> <li>The MCC finalizes the migration schedule for Sprint n, incorporating all corrected supplier plans and ensuring alignment with the migration framework.</li> </ul>	<ul style="list-style-type: none"> <li>Baselined MHHS Migration Schedule for Sprint n</li> </ul>
02.11	<b>Publish and Communicate Migration Schedule</b>	<b>MCC</b>	<ul style="list-style-type: none"> <li>Baselined MHHS Migration Schedule for Sprint n</li> </ul>	<ul style="list-style-type: none"> <li>The finalized migration schedule for Sprint n is published and communicated to all stakeholders, including tailored versions for individual suppliers.</li> <li><u>Including aggregated Supplier plans to assist other participants capacity planning.</u></li> </ul>	<ul style="list-style-type: none"> <li>Published Migration Schedule for Sprint n</li> </ul>
02.12	<b>Sprint n Execution Monitoring</b>	<b>MCC &amp; Suppliers</b>	<ul style="list-style-type: none"> <li>Published Migration Schedule for Sprint n</li> </ul>	<ul style="list-style-type: none"> <li>Both MCC and suppliers monitor the execution of Sprint n against the published schedule, identifying any deviations or issues.</li> </ul>	<ul style="list-style-type: none"> <li>Sprint n Execution Report</li> </ul>
02.13	<b>Sprint n Review and Feedback Collection</b>	<b>MCC</b>	<ul style="list-style-type: none"> <li>Sprint n Execution Report</li> </ul>	<ul style="list-style-type: none"> <li>At the end of Sprint n, conduct a review to assess the sprint's effectiveness, collect feedback from all stakeholders, and identify areas for improvement.</li> </ul>	<ul style="list-style-type: none"> <li>Sprint n Review Report &amp; Stakeholder Feedback</li> </ul>

#	Process Name	Role	Input	Process Details	Output
02.14	<b>Sprint n+1 Planning Preparation</b>	<b>MCC</b>	<ul style="list-style-type: none"><li>• Sprint n Review Report and Stakeholder Feedback</li></ul>	<ul style="list-style-type: none"><li>• Utilize the insights and feedback from Sprint n to begin preparation for Sprint n+1 planning, ensuring continuous improvement.</li></ul>	<ul style="list-style-type: none"><li>• Sprint n+1 Planning Initiation Document</li></ul>

## 7 Appendix

### 7.1 MHHS Migration Business Process Model Notation Key







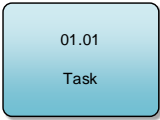

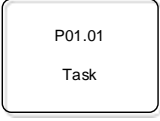

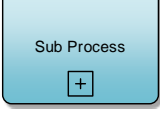
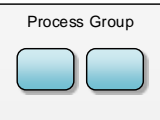

	<b>Start Event</b>		<b>Intermediate Event</b>		<b>End Event</b>
			<b>Process Link</b>		
			<b>Message Event</b>		
			<b>Multiple Triggers</b>		
			<b>Signal</b>		
	<b>Task:</b> This represents a specific action or step in the process				
	<b>Indicative Task:</b> Indicative activity to aid understanding and representative only				
	<b>Sub-Process:</b> A collapsed process comprised of a series of other tasks/processes				
	<b>Process Group:</b> An collapsed view of tasks and/or sub-processes				
	<b>Exclusive (XOR) Gateway:</b> Decision to go one way or another				
	<b>Parallel (AND) Gateway:</b> Initiate multiple steps				
	<b>Inclusive (OR) Gateway:</b> Offers multiple paths but more flexible than the XOR				
	<b>Message Flow</b>				
	<b>Sequence Flow</b>				
	<b>Data Object</b>				

Figure 5 - Business Process Model Notation Key